



BRUSH & TREE DESTROYERS

Heavy-Duty Packages with Seppi Cutting Heads Turn Brush and Trees Into Mulch!

Whether you're looking for a complete package or just a Seppi cutting head to mount on a carrier you already own, **Brush Technology is the only call you should make.**

We'll make sure the system you send into the field is the most efficient, longest lasting, best performing and safest available.

Nobody is better qualified to match brush cutting equipment to your specific application.

- **SEMPI Cutting Heads** are the original, best engineered and longest lasting in the industry.
- **Large, Air Conditioned** and heated cab with great visibility.
- **Hydrostatic Transmission** provides the ideal combination of torque and speed range.
- **All-Wheel Drive Planetary** axles with hydraulic differential lock. Rigid front and oscillating rear.
- **Wide selection of cutting** head sizes assure a perfect match to the carrier and the job at hand.



Comfort, easy-to-use controls & complete instrumentation are standard equipment.

**BRUSH
TECHNOLOGY**

www.brush-technology.com

14375 James Road Rogers, MN 55374
Phone: (763) 428-5099 Fax: 763-428-5051

	SEMPI MODEL	WORKING WIDTH	OVERALL WIDTH	MIN. HP P.T.O.	MAX. HP P.T.O.	NUMBER OF HAMMERS	WEIGHT (LBS.) HEAD (ONLY)	WEIGHT (LBS) HEAD & CARRIER
BARKO 785B	Midiforest 200	6' 7"	7' 5"	80	120	33	2736	25,236
	Midiforest 225	7' 5"	8' 5"	80	120	38	3014	25,514
	Midiforest 250	8' 3"	9' 3"	90	120	42	3190	25,690
	Midiforest dt 200	6' 7"	7' 7"	120	150	33	3077	25,577
	Midiforest dt 225	7' 5"	8' 7"	120	150	38	3696	26,196
	Midiforest dt 250	8' 3"	9' 6"	120	150	42	4180	26,680
BARKO 785B OR 885B*	Forest 200	6' 7"	7' 5"	110	200	33	5412	27,912 30,912*
	Forest 225	7' 5"	8' 3"	130	200	38	5940	28,440 31,440*
	Forest 250	8' 3"	9' 1"	150	200	42	6446	28,946 31,946*
BARKO 885B	Forest dt 200	6' 7"	8' 1"	180	300	42	6688	32,188
	Forest dt 225	7' 5"	8' 8"	190	300	47	7370	32,870
	Forest dt 250	8' 3"	9' 6"	190	300	53	7986	33,486

	Barko 785B	Barko 885B
Engine	Cummins BTA5.9, 168 hp, 2000 rpm, 6 cylinder	Cummins 6CT8.3, 215 hp, 2200 rpm, 6 cylinder
Electrical	12 Volt, 95 amp alternator, dual 31 series batteries	12 Volt, 95 amp alternator, dual 31 series batteries
Fuel Tank	80 gallon	80 gallon
Air Cleaner	Dual-element, dry type with pre-cleaner	Dual-element, dry type with pre-cleaner
Power Train	Hydrostatic transmission with variable displacement pump & motor and dual pilot-operated foot controls. Two-speed transfer case.	Hydrostatic transmission with variable displacement pump and motor and dual pilot-operated foot controls. Two-speed transfer case.
Hydraulics	Variable displacement, load sensing piston pump with 75 gal. reservoir, 10 micron filtration and hi-capacity filter. Main – 35 gpm @ 3,600 PSI Propel – 58 gpm @ 5,000 psi Cutter – 60 gpm @ 4,900 psi	Variable displacement, load sensing piston pump with 75 gal. reservoir, 10 micron filtration and hi-capacity filter. Main – 35 gpm @ 3,600 PSI Propel – 58 gpm @ 5,000 psi Cutter – 75 gpm @ 4,900 psi
Steering	Joystick controlled – 15'-9" turning radius (outside tire)	Joystick controlled – 15'-9" turning radius (outside tire)
Lift & Tilt	Joystick with push button for gate & front differential	Joystick with push button for gate & front differential
Brakes	Foot operated hyd. emergency, hand operated parking	Foot operated hyd. emergency, hand operated parking
Tires	23.1 x 26 - 10 ply, logger type	26 L x 26 - 12 ply, logger type
Travel Speed	Unlocked: Low gear / 0 to 4.6 mph. High / 0 to 11.9 mph.*	Unlocked: Low gear / 0 to 4.6 mph. High / 0 to 11.9 mph.*

* Slightly lower with 23.1 x 26 logger type.

	Barko 785B	Barko 885B
A	21"	21"
B	9' 0"	9' 0"
C	24'	25'
D	10' 7"	10' 7"
E	8' 6"	9' 6"

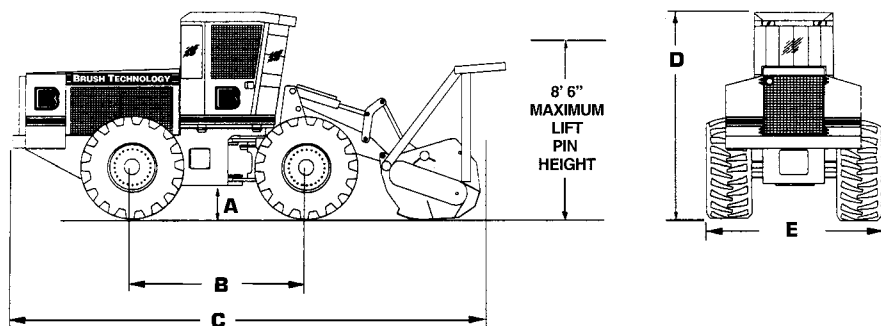

BRUSH TECHNOLOGY

www.brush-technology.com

14375 James Road Rogers, MN 55374
Phone: (763) 428-5099 Fax: 763-428-5051

Features and specifications subject to change without notice.

Proudly distributed by

